

Analog Inputs

Analog inputs are read using a A/D converter or module which has one or more channels of A/D (Analog to Digital) input.

Key Specifications are:

1. Bits of Resolution
2. Range of Voltage Inputs or Sensor Types
3. Input Impedance Specification
4. Single-Ended or Differential Inputs

Resolution

8 bits – 256 steps (0 to 255) over the input voltage range.

10 bits -1024 steps (0 to 1023) over the input range

12 bits – 4096 steps (0 to 4095) over the input range

16 bits – 65535 steps (0 to 65534) over the input range – If one bit is sign bit, positive and negative 32, 767 in each direction.

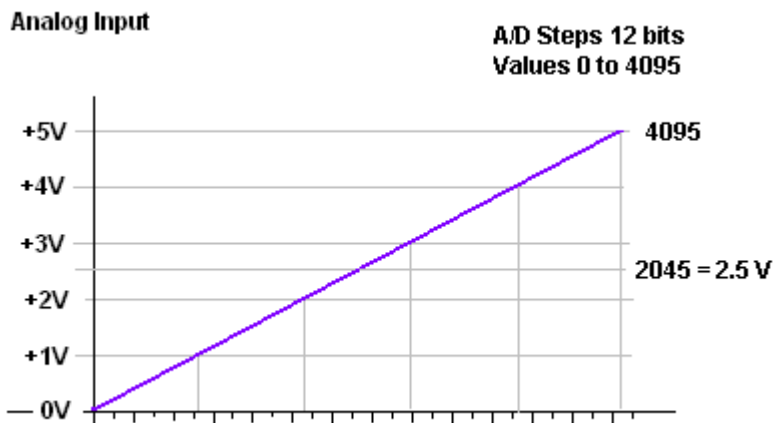

How much resolution is needed? Depends on what is being measured, For example, with 12 bits of resolution, and a range of 0 to 5 volts, each step is about 1.22 mV, If the range is 10 volts, each step is nearly 2.5 mV.

Voltage range divided by the number of steps = the voltage of each step.

If the range is 0 to 20mA we lose everything lower than 4 mA, using 4 to 20 mA. Only 16 mA remain. That means the first 819 steps are lost, leaving 3277 steps of useable range.

Why is 4-20mA analog current loop used?? Current loop is used for analog values because it can go a considerable distance without noise pickup, and also, values below 4 mA can indicate a open/broken wiring connection to the sensor. Current loop is often used to indicate the levels of tanks, oil storage or other liquids. It may also be used to indicate weight with scales having an analog output instead of Digital



International Headquarters: 707 Dayton Road - PO Box 1040 - Ottawa, IL 61350 USA
815-433-5100 Fax 433-5104 www.bb-elec.com orders@bb-elec.com support@bb-elec.com

European Headquarters: Westlink Commercial Park - Oranmore, Co. Galway, Ireland
+353 91 792444 Fax +353 91 792445 www.bb-europe.com orders@bb-europe.com support@bb-europe.com

Current Loop output. (Digital Current loop typically has ASCII characters for scale ID and weight at a baud rate similar to RS232/422/485 data, except for electrical format, which is similar to the old Teletype Machine (TTY) standard.)

Range of Voltage Inputs

+/- 150mV, +/-500mA, +/- 1 V, +/-5 V, +/- 10, +/- 20mA.

Special Sensor Types *1

Thermocouple

Thermocouples are made of two different metals joined together at one end, which produce a voltage over a range of temperatures. One lead is positive, the other is negative. Copper-Nickel (Cu-Ni), Nickel-Aluminum (Ni-Al), Copper-Nickel (Cu-Ni), Platinum-Rhodium (Pt.10%-10%Rh). There are standards for ANSI, IEC, JIS, color codes as well as other standards. (Search engine using Thermocouple Color Codes)

Common types: J, K, T, E, Temperature ranges to 480C (896F)

Less common: R, S, B, G, C, & N. Temperature ranges to 2315C (4200F)

RTD

Resistance Temperature Detectors –formed into a Probe assembly, an element, a sheath, a lead wire, and termination (connector or connection. RTD configurations have 2 connections, or 3 connections (most Standard), two connections to one end of the sensor, the 2nd wire is used for lead resistance compensation. There are 2 kinds of 4 lead RTD, the more common one has a separate lead resistance loop.

Thermistor

Thermally sensitive resistors, NTC (Negative Temperature Coefficient) and PTC (Positive Temp. Coefficient) types. NTC is more popular. Other configurations may have 4 leads

Compared to RTDs:

- Higher resistance change per degree of temperature – greater resolution
- High level of repeatability and stability ($\pm 0.1^{\circ}\text{C}$)
- Excellent interchangeability
- Small size means faster response to temperature changes

Thermistors are available in a variety of resistances and “curves” and the resistance is normally specified at 25°C ((77°F), the most common resistances are:

2252Ω 3000Ω 5000Ω 10,00Ω 30,000Ω 50,000Ω 1 MΩ (1,000,000)

The “curves” rate the resistance change per degree at 50C. Example for 2252 ohms, -30.7 ohms per C. Relatively low temperature (-55C to 70C) generally use low resistance thermistors. Up to 10K ohms)

Flow and Level

pH and Conductivity

Humidity



International Headquarters: 707 Dayton Road - PO Box 1040 - Ottawa, IL 61350 USA
815-433-5100 Fax 433-5104 www.bb-elec.com orders@bb-elec.com support@bb-elec.com

European Headquarters: Westlink Commercial Park - Oranmore, Co. Galway, Ireland
+353 91 792444 Fax +353 91 792445 www.bb-europe.com orders@bb-europe.com support@bb-europe.com

Pressure, Strain, Force

AC or DC Voltage or Current Sensors

If higher DC voltages need to be measured, and the input impedance of the A/D input is high even, say 20M ohms, the high voltage can be divided down with resistors say 100/10 such as is common with a high voltage probe to bring it within range of the meter. Other possibilities are to use an active voltage sensor to output a range of voltage the unit can be set to handle. This sort of device is often needed to inductively measure current flow or AD voltage or current.

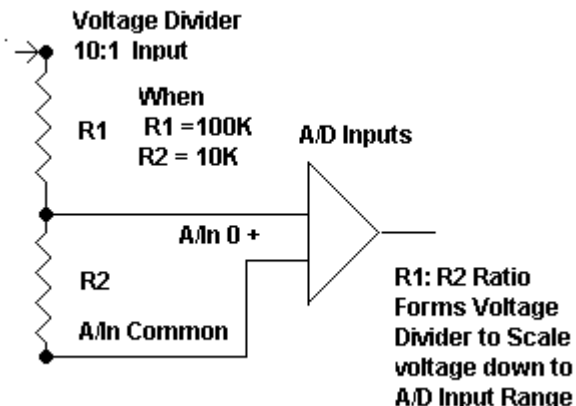

Input Impedance

A high input impedance will not load the voltage being measured to a lower voltage, so when the voltage is measured with a DVM, before connecting the A/D input, it will remain the same voltage after connecting it.

If the input is 0 to 20mA, we need to know what the input impedance is for 20mA. Examples: 120, 124, 125, 500 or 600 ohms or whatever the load rating is. Otherwise the readings will be wrong. On one of the signal conditioners, the input value is 49.9 ohms, and the resistor power rating is .025 watt. The output load however is 600 ohms at 12 VDC.

If a A/D input impedance is 1K or lower, the output impedance of the source needs to be lower than the load. If equal, half the voltage would be lost like a voltage divider with series resistors, RxOut & RxADIn.

Single Ended Inputs: One input is referenced to common/Ground. The input is positive or negative relative to GND.

Differential Inputs – One input is positive, the other input is negative, the A/D reads the difference between them. Differential inputs can cancel noise pickup that is common to both inputs, positive and negative.

Other Considerations - Other important specs are notch filtering for 50Hz or 60Hz hum, low pass filters to eliminate high frequency noise, or external Low Pass filter circuitry must be added.

*1. A good source of sensors and information on various types, probes, sheathing is Omega at www.omega.com with offices in the US, Canada, and other countries. They have technical papers and selection guides for various sensors.



International Headquarters: 707 Dayton Road - PO Box 1040 - Ottawa, IL 61350 USA
815-433-5100 Fax 433-5104 www.bb-elec.com orders@bb-elec.com support@bb-elec.com

European Headquarters: Westlink Commercial Park - Oranmore, Co. Galway, Ireland
+353 91 792444 Fax +353 91 792445 www.bb-europe.com orders@bb-europe.com support@bb-europe.com

-twr2011.04.08